

Work Bench Plans
from
UCNDOIT

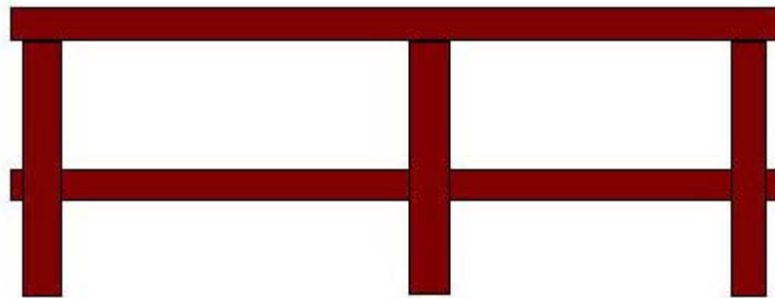

Copyright © Ucndoit 2006

We have included plans to build an 8' work bench with a full length shelf underneath. These plans will allow you to build your bench attached to the wall or free standing.

The wall mounted bench has a 3" overhang from the top shelf to the bottom shelf in the front of the bench.

The free standing bench allows you to have the bench away from the wall with a 3" overhang from the shelf below on the front and back sides.

This project is can be done by one person but is much easier and quicker with 2 people and should take about an hour to complete.

Included:

1. Material and Tools Needed List
2. Material Preparation List
3. Assembly Directions
4. Several Detailed Drawings

Materials

- 1 - Box of 2 ½" Drywall screws
- 1 - Box of 1" Drywall screws
- 1 - Box of 4" Drywall screws or 4" lag bolts (wall mount bench only)
- 1 - 4'x8' sheet of plywood (½" or thicker recommended)
- 8 - 2"x4"x8' for wall mounted bench
- Or
- 9 - 2"x4"x8' for free standing bench

Tools

Circular Saw

Screw Driver/Drill

Tape Measure

Level (opt)

Safety Equipment (Safety is YOUR responsibility)

Material Prep

The first step is to decide on whether you want to mount the bench directly to the wall or do you want the bench to be free standing. Mounting to the wall keeps the bench more stable when working on it; however there is the flexibility of moving it around if it is a free standing bench. I have used this bench in both configurations and was happy with each design.

Once you have decided which style you want, you will need to cut the wood for the style you have chosen. Below are all of the cuts necessary for each style.

Notes:

- Pre-drill all screws to prevent splitting wood!
- All measurements assume that a 2x4's actual measurements are 1 ½ x 3 ½
- All safety precautions are YOUR responsibility to know!

Wall Mounted Bench

Cut Plywood:

1 piece @ 25 ½" x 96"

1 piece @ 22 ½" x 96"

Cut 2" x 4":

2 @ 36", 22 ½", 22 ½"

1 @ 36", 22 ½", 19 ½"

1 @ 19 ½", 19 ½", 19 ½"

Free Standing Bench

Cut Plywood:

1 piece @ 27" x 96"

1 piece @ 21" x 96"

Cut 2"x 4":

3 @ 36", 36", 24"

1 @ 18", 18", 18", 18", 24"

1 @ 24"

Assembly

First assemble the framing for the top shelf and the bottom shelf according to the diagrams included. Figures 1 and 2 are for the wall mounted bench and Figures 1A and 2A are for the free standing bench. Once the shelf frames are completed, follow the instructions below to assemble your new bench:

Wall Mounted Bench assembly:

1. Attach the 3 legs to the bottom shelf with 3 - 2 ½" screws each about 1 foot high (Fig 3).
 2. Next, after making sure it is safe* to screw into the wall, use a level for proper alignment, then attach the back board of bottom shelf to wall with three 4" screws at each wall stud. (Fig 3)
 3. Attach the 22 ½" x 96" plywood to top of the bottom shelf using 1" screws.
 4. Attach the top shelf to the legs with 2 ½" screws (Fig 4) so that the top of the legs are even with the top of the shelf, then attach to wall the same way as with the bottom shelf.
 5. Attach the 25 ½" x 96" plywood to the top shelf with 1" screws all the way around.
- **Check for hidden obstacles behind walls such as electrical wires, plumbing, etc. Safety is YOUR responsibility!**

Free Standing Bench assembly:

1. Attach the 36" legs to the bottom shelf as shown in Figure 3A. Use 3- 2 ½" screws on each leg using a triangular pattern. The height of this shelf depends on your needs. If you are not sure, attach it about 1 foot off the ground. It can always be raised or lowered later if needed.
2. Attach 21"x96" plywood to bottom shelf using 1" screws about 1" apart all the way around.
3. Next, set the top shelf over the legs (Fig 4A) so that the top of the legs are even with the top of the shelf. Attach using 3 -2 ½" screws using a triangular pattern on each leg.
4. Attach 27" x 96" plywood to the top using 1" screws about 1 foot apart all the way around.

Figure 1

Wall Mounted Bench

Top Shelf

2 1/2" Drywall screws

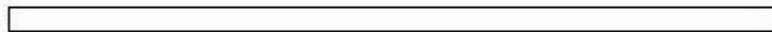

2 long rails - 2x4x96

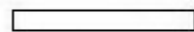

5 crossmembers - 2x4x22.5

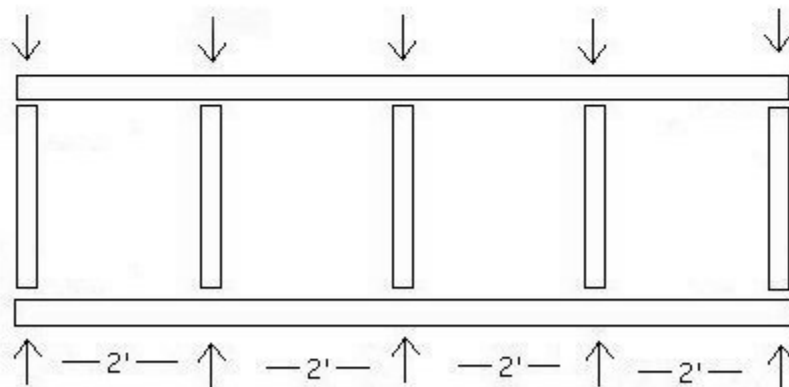

↑ = Put 2 - 2 1/2" screws in at each arrow in direction indicated

Once completed, set to the side and build bottom shelf

Figure 2

Wall Mounted Bench

Bottom Shelf

2 1/2" Drywall screws

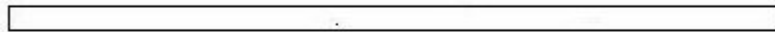

2 long rails @ 2x4x96

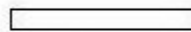

4 crossmembers @ 2x4x19.5

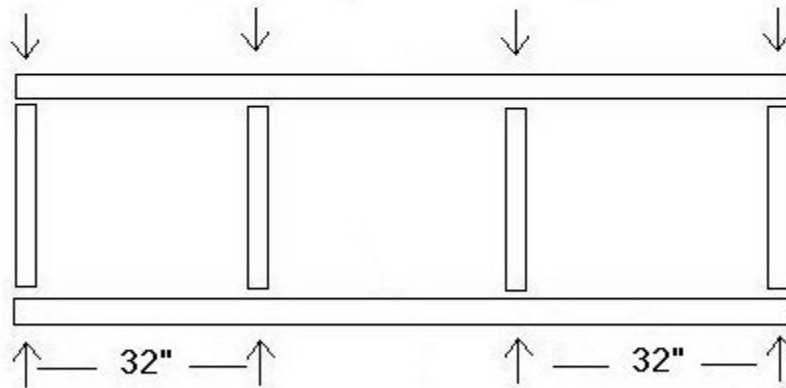

↑ = Put 2 - 2 1/2" screws in at each arrow in direction indicated

Figure 3
Wall Mounted Bench
Bottom Shelf

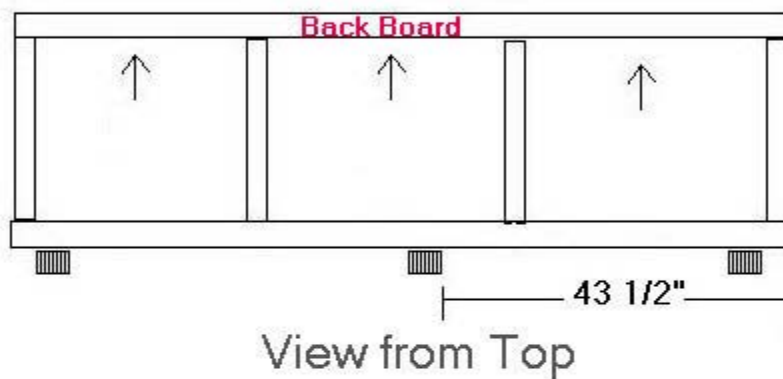

↑ Attach 3 - 4" screws through backboard into each wall stud

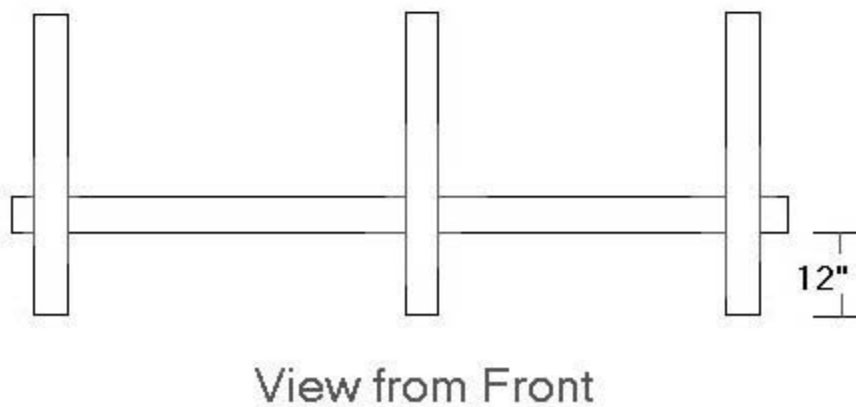
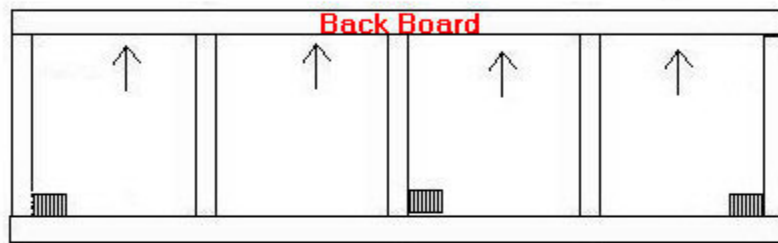

Figure 4

Wall Mounted Bench

Top Shelf



View from Top

↑ Attach 3 - 4" screws through backboard into each wall stud

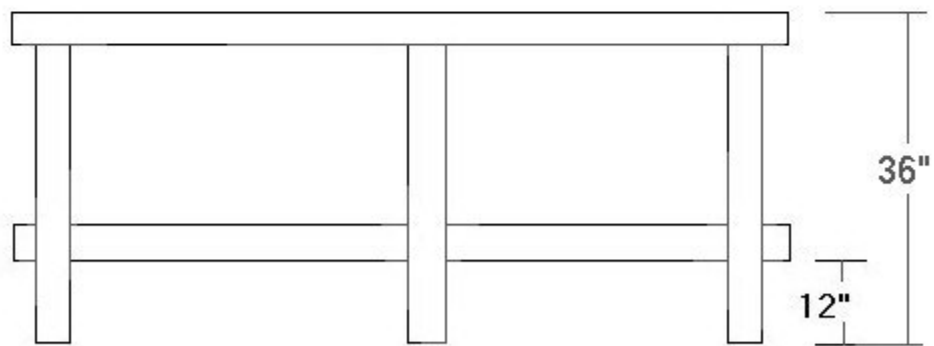

View from Front

Figure 1A

Freestanding Bench

Top Shelf

2 1/2" Drywall screws

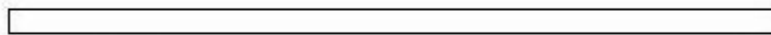

2 long rails @ 2x4x96

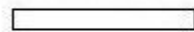

5 crossmembers @ 2x4x24

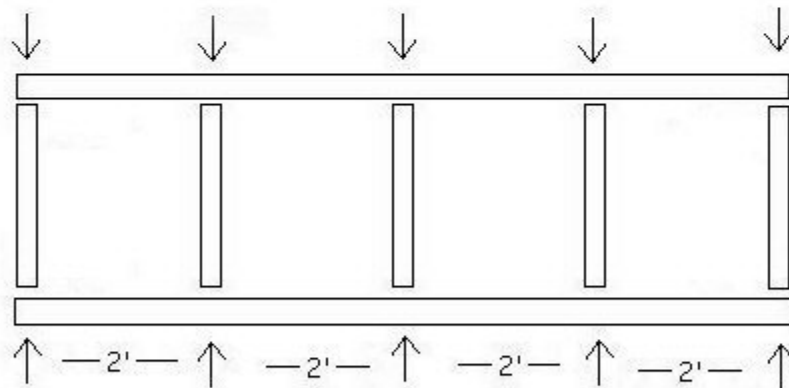

↑ = Put 2 - 2 1/2" screws in at each arrow in direction indicated

Once completed, set to the side and build bottom shelf

Figure 2A

Freestanding Bench

Bottom Shelf

2 1/2" Drywall screws

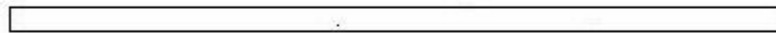

2 long rails @ 2x4x96

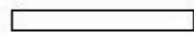

4 crossmembers @ 2x4x18

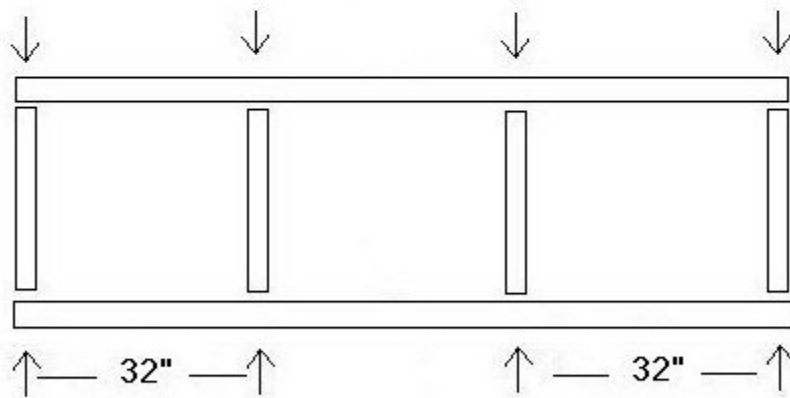

↑ = Put 2 - 2 1/2" screws in at each arrow in direction indicated

Figure 3A
Freestanding Bench
Bottom Shelf

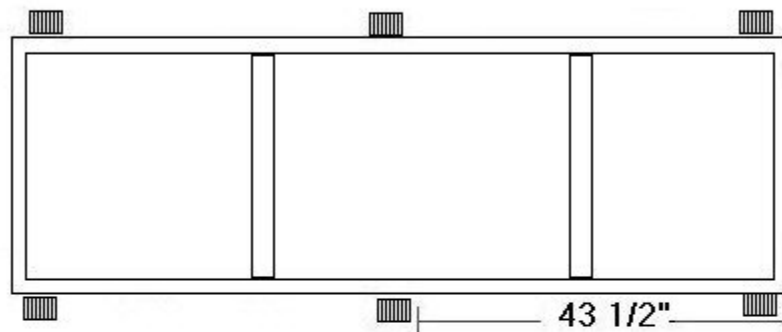

Completed View From Top

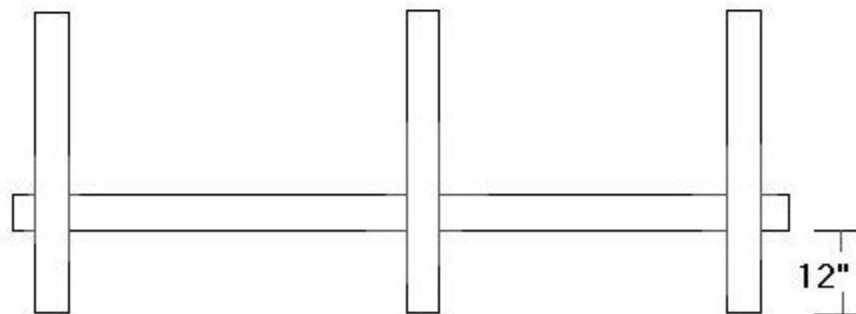

View from Front

Figure 4A
Freestanding Bench
Top Shelf

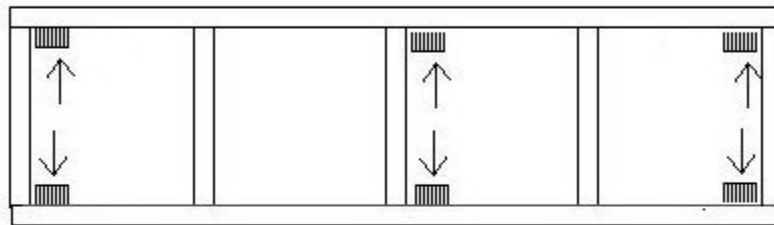

Top View of Legs in Top Shelf

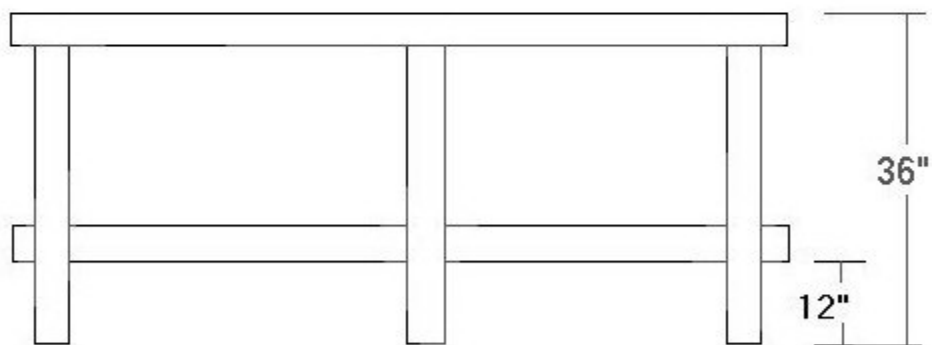

View from Front